

Product code: AM005

# AMAZON

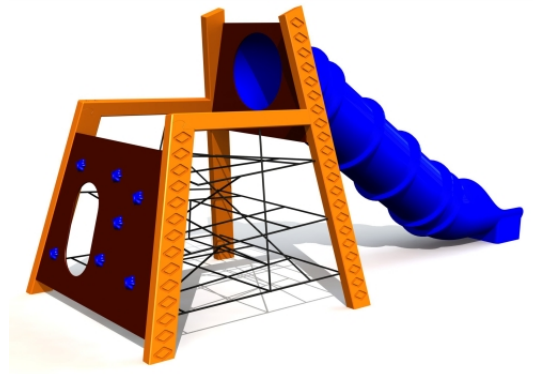

4 y



2 m



2.26 m



6.02 m



3 m

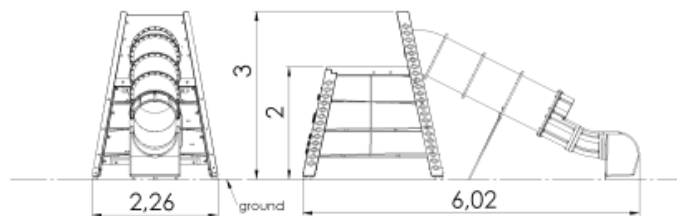
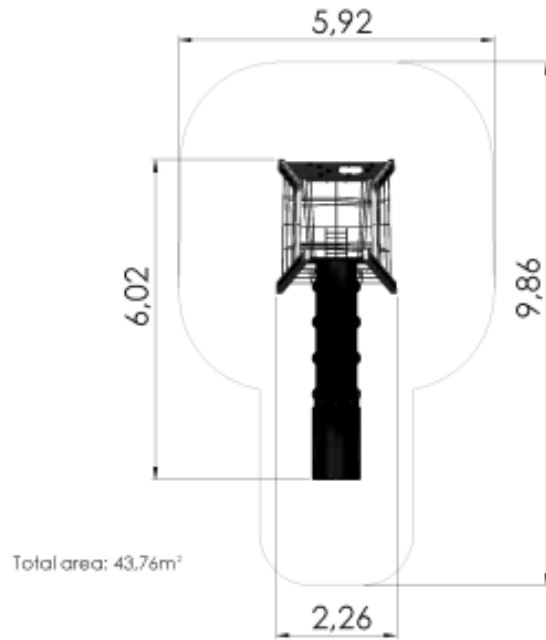

## Technical information

Safety area width	5.92 m
Safety area length	9.86 m
Width of structure	2.26 m
Length of structure	6.02 m
Height of structure	3 m
Max. fall height	2 m
Recommended age of children	4+
For simultaneous use by several children	1-6

## Installation info

Installers	2	The product needs a safety surface
Installation time	7 h	
Volume of concrete	20 bags (25kg)	
Package weight	310 kg	

The unique AMAZON climbing frame is made of durable laminated timber and it has been awarded the relevant quality certificates. Posts of laminated timber decorated with different ornaments are joined together using the innovative mortise joint. The cross-section of the posts is 100mm x 236mm and the nets between them are made of extremely durable 16mm steel rope designed for climbing which is coated with polyester and features plastic joints. This functional climbing frame offers various climbing, balancing and crawling opportunities. The laminated and painted timber posts are concreted to the ground using hot-dipped galvanized metal fittings.