

Product code: OCT002

Swing OCTO 2 seats (without seats)



4 y



1.35 m



2.46 m



3.74 m



2.46 m

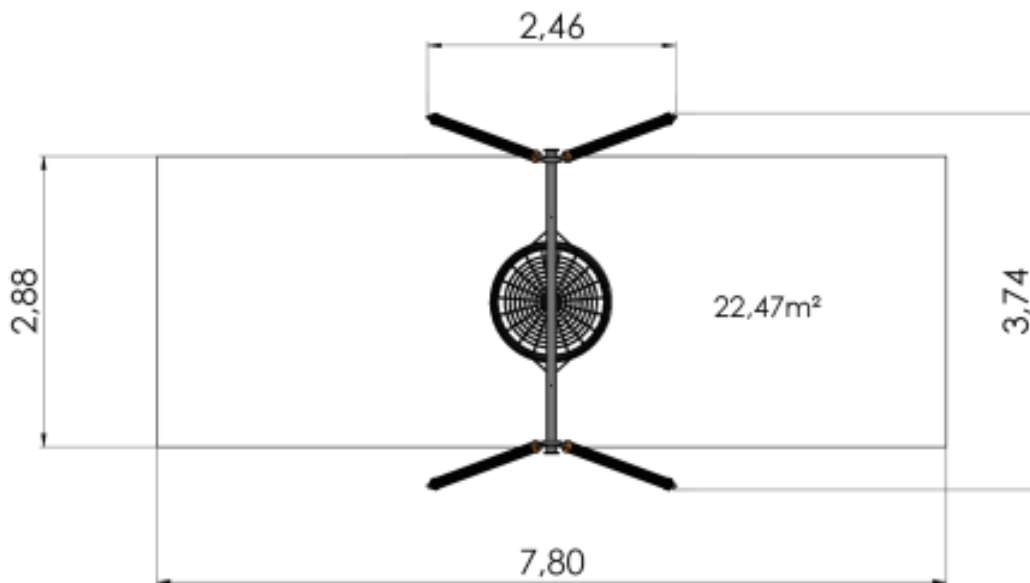

Technical information

Safety area width	2.88 m
Safety area length	7.8 m
Width of structure	2.46 m
Length of structure	3.74 m
Height of structure	2.46 m
Max. fall height	1.35 m
Recommended age of children	4+
For simultaneous use by several children	1-4

Installation info

Package dimensions	3,0x0,75x0,8m
--------------------	---------------

The OCTO series products are designed to offer physical challenges and developmental activities to older children who are burning with a desire to test themselves. The products from this series allow one to test their endurance, coordination, balance and definitely courage.

The product range with an innovative design is constantly expanding. You can choose between large and powerful mega complexes, different climbing frames, spinners, shakers, swing constructions, etc.

The OCTO series is named after innovative octagonal powder-coated aluminum posts. The solid gray colour of the posts makes them suitable for even the most modern environments while the acrylic glass panels only deepen the impression of glazed high-rise buildings. In reality, OCTO® glass panels are made of the same type of durable panels that are used on hockey pitches.