

Product code: OCT101

# Climbing frame OCTO



4 y



2.1 m



1.2 m



6.18 m



3.45 m

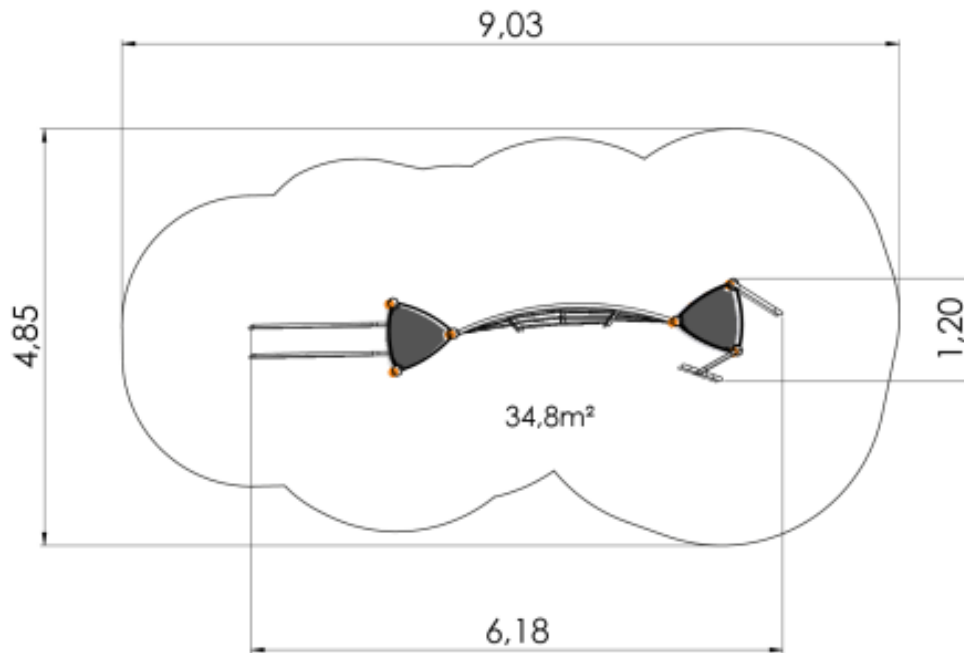

## Technical information

Safety area width	4.85 m
Safety area length	9.03 m
Width of structure	1.2 m
Length of structure	6.18 m
Height of structure	3.45 m
Max. fall height	2.1 m
Recommended age of children	4+
For simultaneous use by several children	1-8

## Product consists of

Platforms	1 pcs with a height 1.86 m
Platforms	1 pcs with a height 1.55 m

## Installation info

Package dimensions	4,1x1,0x1,0m
--------------------	--------------

The series was named after modern octagonal powder coated aluminium posts. The series is like a large city where everyone feels able to win through! The product range of the series of particular design meant for the young is expanding continually. The OCTO series acrylic glass panels accentuate the impression of high-rise glass buildings. In reality, the durable glasspanels are of the type known from hockey squares. The attractions survive even the biggest challenges. The OCTO series offers developing activities and physical effort for older children who ardently wish to try their hand. The selection includes big and grand megacomplexes, different climbing facilities, spinners, shakers, swing constructions etc. A new meeting place was born!