

Product code: OCT107-1

Climbing complex OCTO 7.1



4 y



2.29 m



5.5 m



11.25 m



3.92 m

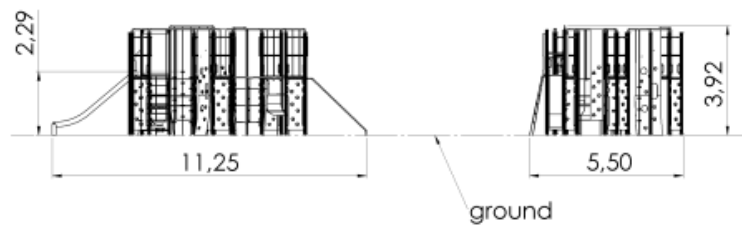
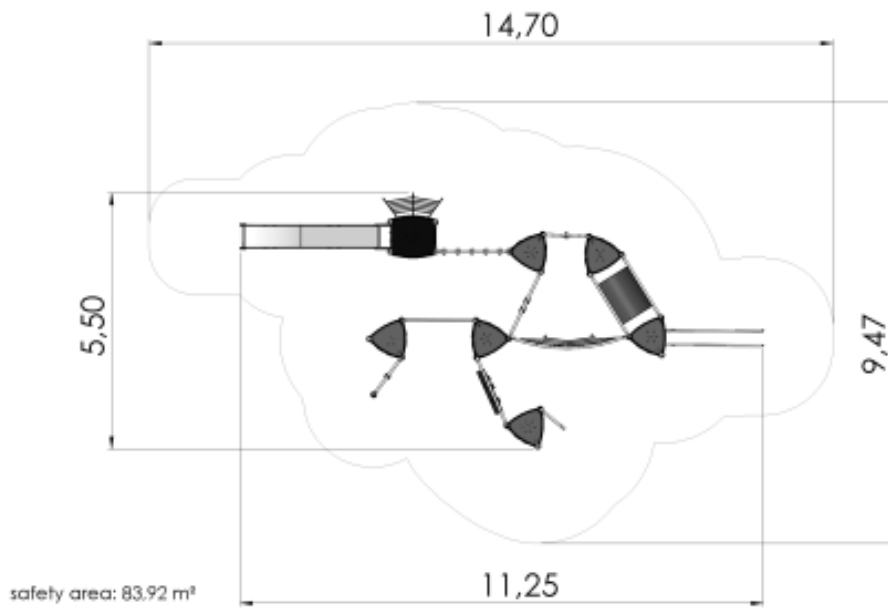

Technical information

Safety area width	9.47 m
Safety area length	14.7 m
Width of structure	5.5 m
Length of structure	11.25 m
Height of structure	3.92 m
Max. fall height	2.29 m
Recommended age of children	4+
For simultaneous use by several children	1-25

Product consists of

Platforms	6 pcs with a height 2 m
Platforms	1 pcs with a height 2.15 m
Slides	1 pcs with a height 2.15 m Stainless-steel, HDPE plastic sides
Railings	2 pcs with a height 2 m Stainless steel
Climbing walls	10 pcs
Climbing nets	1 pcs 16 mm six-strand PES cover braided steel ropes
Slopes	1 pcs
Fireman poles	1 pcs Galvanized and powder-coated steel
Play corners	1 pcs Plastic and wood
Posts	23 pcs

The series was named after modern octagonal powder coated aluminium posts. The series is like a large city where everyone feels able to win through! The product range of the series of particular design meant for the young is expanding continually. The OCTO series acrylic glass panels accentuate the impression of high-rise glass buildings. In reality, the durable glasspanels are of the type known from hockey squares. The attractions survive even the biggest challenges. The OCTO series offers developing activities and physical effort for older children who ardently wish to try their hand. The selection includes big and grand megacomplexes, different climbing facilities, spinners, shakers, swing constructions etc. A new meeting place was born!