

Product code: LM002 AUT PE

Slide ANN



1 y



0.95 m



0.95 m



3.44 m



2.65 m

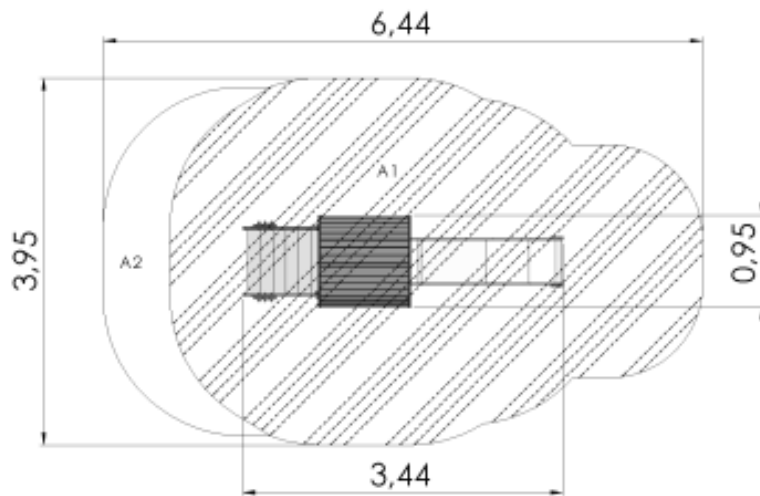

Critical fall height(CFH)
A1: CFH 0.95m - 18.05m²
A2: CFH 0.6m - 2.66m²
Total area: 20.71m²

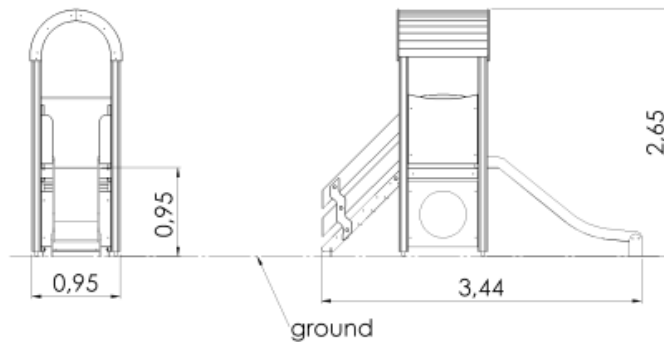

Technical information

Safety area width	3.95 m
Safety area length	6.44 m
Width of structure	0.95 m
Length of structure	3.44 m
Height of structure	2.65 m
Max. fall height	0.95 m
Recommended age of children	1+
For simultaneous use by several children	3-6

Product consists of

Platforms	1 pcs with a height 0.95 m Laminated wood
Roofs	1 pcs HDPE plastic
Slides	1 pcs with a height 0.95 m Stainless-steel, HDPE plastic sides
Stairs with handrails	1 pcs Laminated wood
Posts	4 pcs Laminated wood
Panels/Plates	5 pcs HDPE plastic
Tubes	1 pcs Galvanized and powder coated steel

Installation info

Installers	2
Installation time	5 h
Volume of concrete	9 bags (25kg)
Package dimensions	2,2x1,0x1,4m
Package weight	174 kg

A toddler slide with a roof and stairs with handrails. The side panels of the slide can be switched for various activity walls or thematic printed panels (animals, birds, fish, trees, berries, etc.). The design of the panels will be finalised with the client during ordering.