

Product code: LM200 AUT PE

Slide LARS



1 y



1.75 m



1.78 m



3.74 m



2.16 m

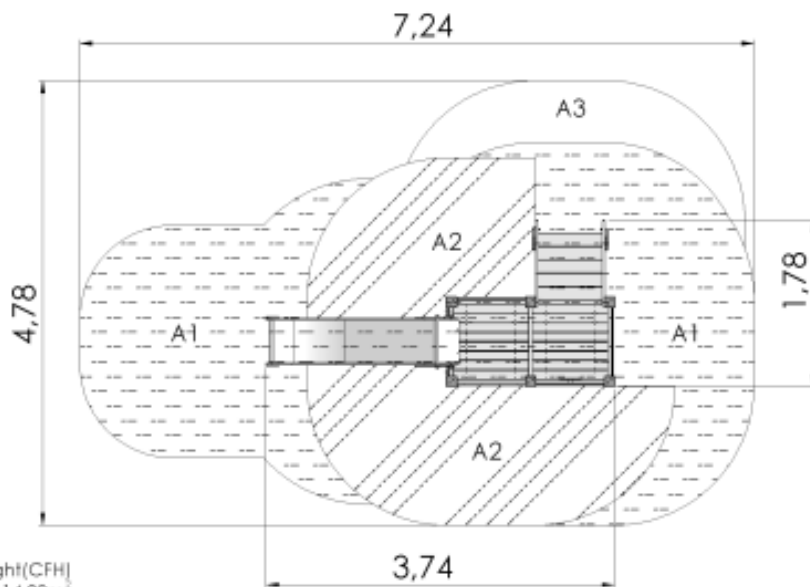

Critical fall height (CFH)
A1: CFH 1,0m - 14,88m²
A2: CFH 1,55m - 8,81m²
A3: CFH 1,67m - 2,21m²
Rubber surface area - 23,69m²
Total area: 25,9m²

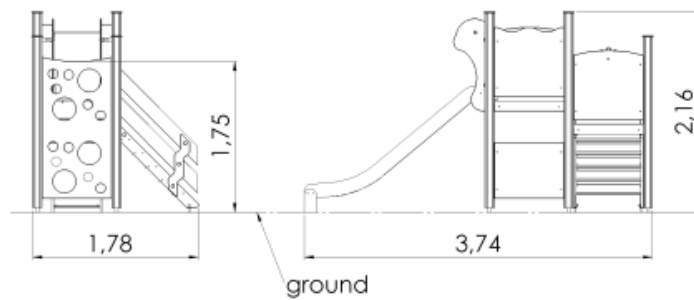

Technical information

Safety area width	4.78 m
Safety area length	7.24 m
Width of structure	1.78 m
Length of structure	3.74 m
Height of structure	2.16 m
Max. fall height	1.75 m
Recommended age of children	1+
For simultaneous use by several children	5-10

Product consists of

Platforms	1 pcs with a height 1.2 m Laminated wood
Platforms	1 pcs with a height 0.95 m Laminated wood
Slides	1 pcs with a height 1.2 m Stainless-steel, HDPE plastic sides
Climbing walls	1 pcs HDPE plastic
Stairs with handrails	1 pcs Laminated wood
Play corners	1 pcs Plastic and wood
Activity panels	2 pcs HDPE plastic
Posts	6 pcs Laminated wood
Panels/Plates	4 pcs HDPE plastic
Tubes	1 pcs Galvanized and powder coated steel

Installation info

Installers	2
Installation time	6 h
Volume of concrete	12 bags (25kg)
Package dimensions	2,4x1,0x0,9m
Package weight	250 kg

The product needs a safety surface

A slide with two platforms, a climbing wall, and stairs with handrails. The slide comes equipped with a captain's helm and a play corner with a bench, which can be fitted with either kitchen or car dashboard elements. The side panels of the play centre can be switched for various activity walls or thematic printed panels (animals, birds, fish, trees, berries, etc.). The design of the panels will be finalised with the client during ordering.