

Product code: CON101

URBAN



8 y



2.5 m



2.2 m



5.33 m



2.5 m

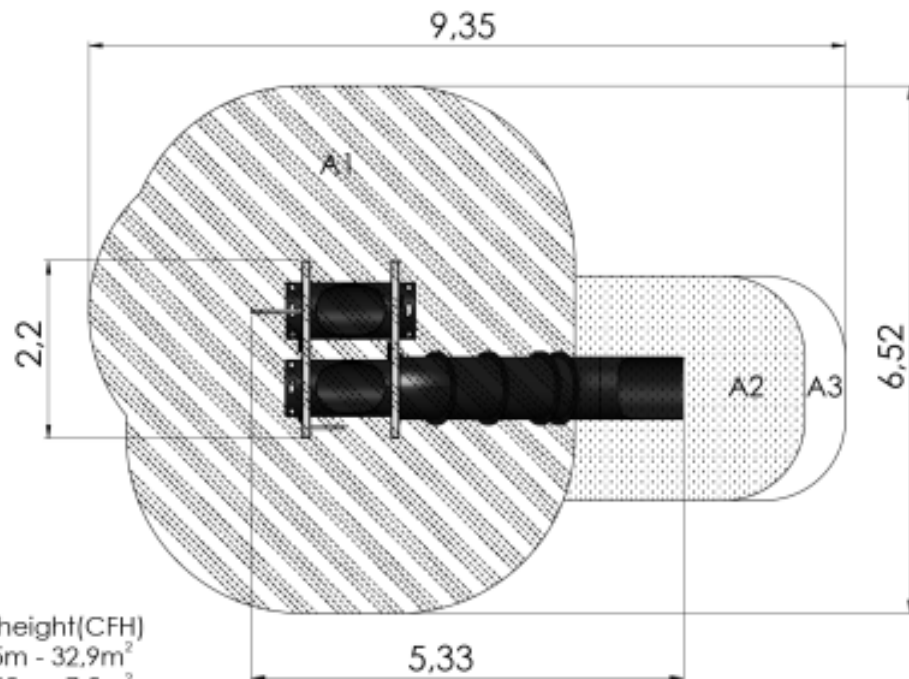
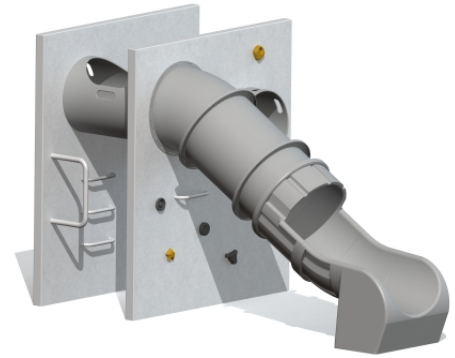

Critical fall height (CFH)
A1: CFH 2,5m - 32,9m²
A2: CFH 1,55m - 7,5m²
A4: Falling space area - 1,4m²
Total area: 41,8m²

Technical information

Safety area width	6.52 m
Safety area length	9.35 m
Width of structure	2.2 m
Length of structure	5.33 m
Height of structure	2.5 m
Max. fall height	2.5 m
Recommended age of children	8+
For simultaneous use by several children	1+

Product consists of

Tunnel slides	1 pcs with a height 0 m Plastic
Tunnels	2 pcs Plastic

Installation info

Package dimensions	2,5x2,4x1,7m
Package weight	320 kg

Stainless steel tubes, strips, platforms and weatherproof textured wear-resistant plywood walls imitating concrete look – the strong look of the URBAN series products is created by high-quality materials that ensure resistance to weather and vandalism. The URBAN theme series can be assembled into a powerful town but each attraction is also challenging on their own.

Materials

Edge profile: stainless steel

Inner frame: hot galvanised steel

Platforms: hot galvanised steel frame with stainless steel plating

Panels: weatherproof textured grey plywood with thick, wear-resistant phenolic coating and concrete imitation

Climbing stones: high quality polyresin with metal washer inserted

Tubes, ladders, parallel sliding bars: stainless steel

Fixings: stainless steel.

Tunnels and tunnel slides: PE plastic